

L'unità di pesatura è stata progettata per facilitare l'installazione diretta della cella F1 in sistemi di pesatura e dosaggio nei serbatoi, silos, tramogge statiche o soggette a vibrazioni.

E' realizzata interamente in acciaio Inox ed è dotata di supporto con elastomero per mantenere elevate caratteristiche anche in presenza di assestamenti, dilatazioni termiche, errori di posizionamento, spinte trasversali, deformazioni delle strutture e vibrazioni.

E' completa di STOP meccanico regolabile per protezione da sovraccarichi e di protezione elettrica contro le scariche elettrostatiche.

This weighing unit is designed to ease the installation of F1 load cell in weighing and batching systems in tanks, silos and hoppers. It is suitable for applications static or subjected to vibrations.

Executed in stainless steel, the weighing unit is provided with an elastomer bearing to preserve excellent features even in event of settlings, thermal dilation, positioning error, transverse thrusts and deformations or vibrations of structures.

It is completed by an adjustable mechanical STOP to protect from overloading and by an electrical protection against electrostatic discharges.

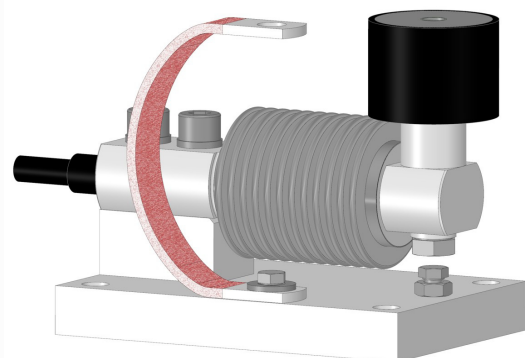
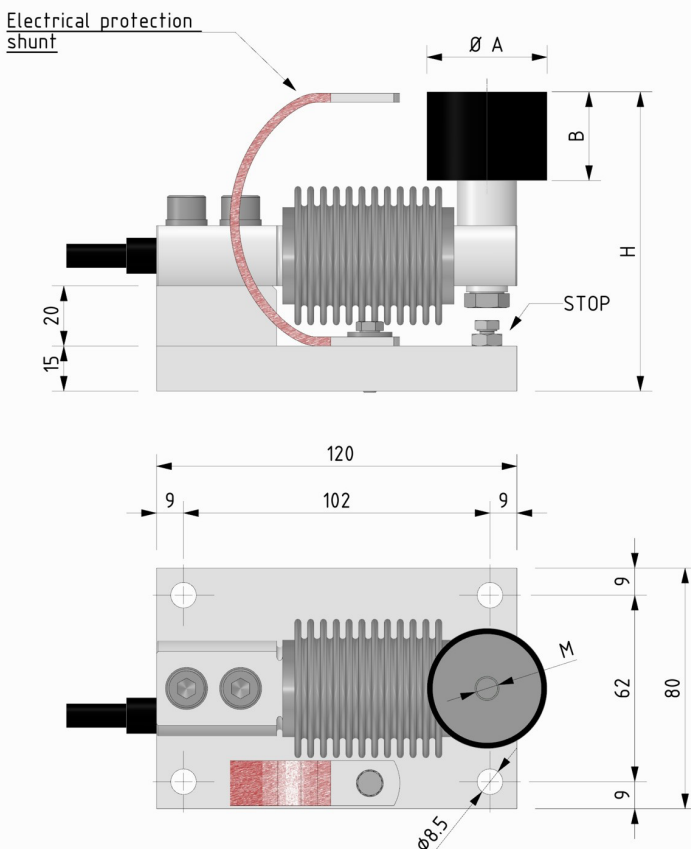
Basso profilo**Alta stabilità a lungo termine****Facile applicazione****Low profile****Long term high stability****Easy application****Dimensioni****Dimensions****[mm]**

RANGE	A	B	M	H
2.5 - 5 - 10 - 20 - 25 - 50kg	40	30	M8	100
100kg - 200kg	50	45	M10	115

Le caratteristiche tecniche delle celle di carico sono elencate nel data sheet F1.103

Technical data of the load cells are listed in data sheet F1.103

Schema di montaggio

Mounting plan

Sistema circolare a 3 punti di appoggio.

Circular system with 3 supporting points.

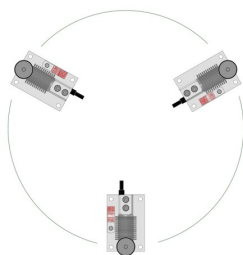

Sistema quadro a 4 punti di appoggio.

Square system with 4 supporting points.

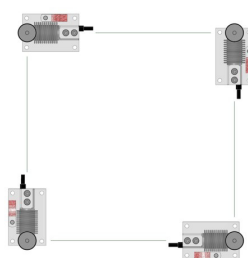

ISTRUZIONI PER IL MONTAGGIO

1. Fissare la piastra inferiore delle unità a terra mediante bulloneria M8.
2. Fissare il sistema da pesare sull'elastomero mediante bullone M8 o M10.
3. Regolare lo **STOP** di sovraccarico in modo da lasciare una luce di 0.2 mm quando il sistema è caricato con il massimo peso.
4. Predisporre una corretta messa a terra di linea delle unità di pesatura installate, rispettando le normative vigenti di impiantistica.

ASSEMBLY INSTRUCTIONS

1. Fix the lower plates of the unit to the floor using M8 bolts.
2. Fix the weighing system to the upper plates of the unit using M8 or M10 bolt.
3. Adjust the overload **STOP** so that a clearance of 0.2 mm is present when the system is loaded with the maximum weight.
4. Connect the weighing units in use to the electrical earth, in accordance with plant design regulations in force.



ATTENZIONE



Si raccomanda di rispettare sempre tutte le normative di sicurezza presenti nel paese in cui viene installata l'unità di pesatura.

Sarà cura dell'installatore effettuare una accurata analisi dei rischi ambientali (zone sismiche, vento ecc).

Durante tutte le fasi del montaggio è necessario evitare accidentali sovraccarichi alle celle di carico.

Evitare il passaggio di corrente attraverso la cella di carico.

Durante le operazioni di saldatura posizionare la pinza di massa nella parte superiore all'unità di pesatura.

Durante la manutenzione verificare che gli **STOP** di sovraccarico siano in posizione corretta e puliti da eventuali residui di materiale.



WARNING



It is recommend to always observe scrupulously all the safety laws present in the country where the unit has to be installed.



The personnel who're going to install the unit shall perform a careful environmental risk analysis (seismic zones, wind etc).

Take care to avoid accidental overloads of the load cells while assembling the unit.

Be sure current does not pass through the load cell.

While welding, connect the ground clamp to the top of the weighing unit.

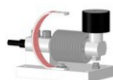
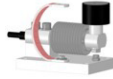
During maintenance check that overload **STOPS** are in correct position and clean of any residual material.

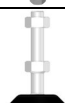
CODICE / CODE	Descrizione	Description
 UPF1	Unità di pesatura da 2,5 a 50 kg COMPLETA di base e elastomero. (cella esclusa)	Weighing unit for 2.5kg to 50kg range COMPLETE of base and elastomer. (load cell not included)
 UPF1B	Unità di pesatura da 100 e 200 kg COMPLETA di base e elastomero. (cella esclusa)	Weighing unit for 100 and 200 kg range COMPLETE of base and elastomer. (load cell not included)
 CANTIVIBRANTEF1	Elastomero per carichi da 2,5 a 50 kg	Elastomer for loads from 2.5 to 50 kg
 CANTIVIBRANTEF1-200	Elastomero per carichi da 100 e 200 kg	Elastomer for loads of 100 and 200 kg
 PDM8	Piede snodato completo di dadi di fissaggio M8.	Articulated leveling foot complete of M8 fixing bolts

Esempi d'installazione *Examples of installation*

Piattaforma a 4 punti di appoggio con piedi snodati standard.
Platform with 4 supporting points with jointed standard feet.

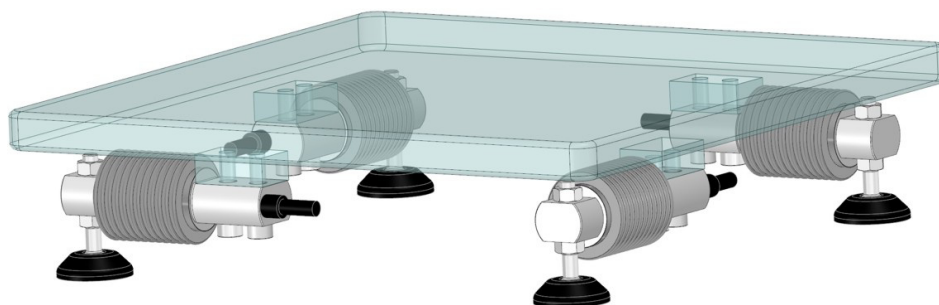

Silos a 3 punti di appoggio.
Silo with 3 supporting points



AEP transducers



Dasa-Rägister
EN ISO 9001:2008
IQ-1100-01

ACCREDIA
L'ENTE ITALIANO DI ACCREDITAMENTO

LAT N° 093
Calibration Centre
The products are NOT
covered by accreditation

ATEX 

Production Quality
Assurance Certified n°
TÜV 06 ATEX 553793 Q

41126 Cognento (MODENA) Italy Via Bottego 33/A Tel:+39-(0)59-346441 Fax:+39-(0)59-346437 E-mail: aep@aep.it

Al fine di migliorare le prestazioni tecniche del prodotto, la società si riserva di apportare variazioni senza preavviso.
In order to improve the technical performances of the product, the company reserves the right to make any change without notice.