

Linearità - Isteresi
 $\leq \pm 0.20\%$
Linearity - Hysteresis

Linearità - Isteresi
 $\leq \pm 0.10\%$
Linearity - Hysteresis

Download on www.aep.it

SOLLECITAZIONI DINAMICHE
DYNAMIC STRESSES

€ LOW COST



Alta Affidabilità
High Reliability

Stabilità a lungo termine
Long term high stability

ACCREDIA
L'ENTE ITALIANO DI ACCREDITAMENTO

LAT N° 093
Calibration Centre
The products are NOT covered by accreditation

Certificato di Taratura ACCREDIA
A RICHIESTA

ACCREDIA Calibration Certificate
ON REQUEST

Dimensioni *Dimensions*

[mm]

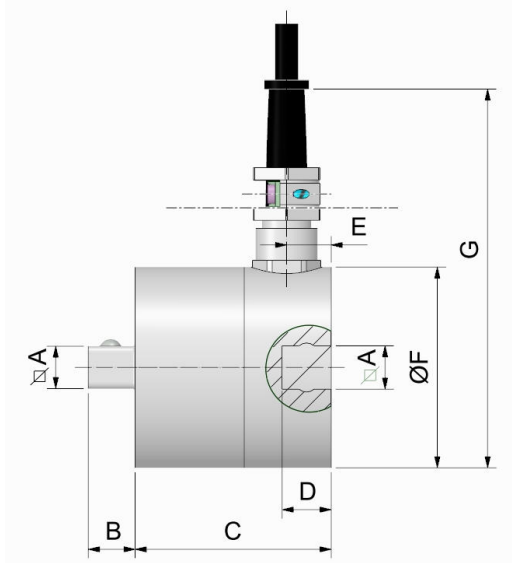

CODE	LOAD	■ A	B	C	D	E	F	G
⁽¹⁾ MTRS05NM	0.5 N·m	1/4"	7.5	44	8	10	45	85
⁽¹⁾ MTRS2.5NM	2.5 N·m	1/4"	7.5	44	8	10	45	85
MTRS5NM	5 N·m	1/4"	7.5	44	8	10	45	85
MTRS10NM	10 N·m	1/4"	7.5	44	8	10	45	85
MTRS25NM	25 N·m	3/8"	10.5	44	11	10	45	85
MTRS50NM	50 N·m	3/8"	10.5	44	11	10	45	85
MTRS100NM	100 N·m	1/2"	15.0	44	16	10	45	85
MTRS250NM	250 N·m	1/2"	15.0	44	16	10	45	85
MTRS500NM	500 N·m	3/4"	22.5	53.5	24	17.5	51	91
MTRS1KNM	1000 N·m	3/4"	22.5	53.5	24	17.5	51	91

(1) La taratura ACCREDIA NON può essere eseguita dal Centro LAT N° 093, a richiesta può essere commissionata ad altri Centri di taratura accreditati.
ACCREDIA certification can NOT be performed by LAT n° 93 Laboratory, on request it can be ordered to other Accredited Laboratories.

Dati Tecnici
Technical Data

TORSIONE NOMINALE STATICA	STATIC NOMINAL TORQUE	0.5* - 2.5 N·m 5 - 10 - 25 - 50 - 100 N·m 250 - 500 - 1000 N·m
LINEARITA' e ISTERESI	LINEARITY and HYSTERESIS	≤ ± 0.20 % (see options)
EFFETTO DELLA TEMPERATURA (1°C): a) sullo zero b) sulla sensibilità	TEMPERATURE EFFECT (1°C): a) on zero b) on sensitivity	≤ ± 0.02% ≤ ± 0.02%
SENSIBILITA' NOMINALE TOLLERANZA DI CALIBRAZIONE	NOMINAL SENSITIVITY SENSIVITY TOLERANCE	2mV/V (*0.5N·m: 1mV/V) ≤ ± 0.5%
Resistenza di ingresso Resistenza di uscita	Input resistance Output resistance	825 ± 50Ω 700 ± 2Ω
ALIMENTAZIONE NOMINALE ALIMENTAZIONE MAX. RESISTENZA DI ISOLAMENTO BILANCIAMENTO DI ZERO	NOMINAL POWER SUPPLY MAX. POWER SUPPLY INSULATION RESISTANCE ZERO BALANCE	1-15V 18V >2 GΩ ≤ ± 1%
VALORI MECCANICI LIMITE RIFERITI ALLA TORSIONE NOMINALE: a) torsione di servizio b) torsione limite c) torsione di rottura d) torsione altamente dinamica	LIMIT MECHANICAL VALUES REFERRED TO NOMINAL TORQUE: a) service torque b) max. permissible torque c) breaking torque d) highly dynamic torque	100% 150% >300% 70%
TEMPERATURA DI RIFERIMENTO TEMPERATURA DI ESERCIZIO TEMPERATURA DI STOCCAGGIO	REFERENCE TEMPERATURE WORKING TEMPERATURE RANGE STORAGE TEMPERATURE RANGE	+23°C -10/+70°C -20/+80°C
CLASSE DI PROTEZIONE (EN 60529) MATERIALE PARTE SENSORE CONNESSIONE ELETTRICA	PROTECTION CLASS (EN 60529) SENSOR EXECUTION MATERIAL ELECTRICAL CONNECTION	IP40 INOX 17-4 PH Cavo / Cable 5m
ATTACCO DI PROCESSO (UNI ISO 1174-1): 0.5 - 2.5 - 5 - 10 N·m 25 - 50 N·m 100 - 250 N·m 500 - 1000 N·m	PROCESS COUPLING (UNI ISO 1174-1): 0.5 - 2.5 - 5 - 10 N·m 25 - 50 N·m 100 - 250 N·m 500 - 1000 N·m	■ 1/4" ■ 3/8" ■ 1/2" ■ 3/4"

Opzioni:

- LINEARITA' e ISTERESI ≤ ± 0.10 %

Options:

- LINEARITY and HYSTERESIS ≤ ± 0.10 %

COPPIA NOMINALE	NOMINAL TORQUE	N·m	0.5	2.5	5	10	25	50	100	250	500	1000
Carico assiale limite	Max axial permissible load	kN	0.38	0.38	0.5	0.9	2.2	3.5	6	9.5	18	28
Carico laterale limite	Max lateral permissible load	N	15	15	15	30	30	80	150	180	250	400
Mom. flettente limite	Bending limit moment	N·m	1	1	1.5	3.5	4.5	15	20	42	65	170

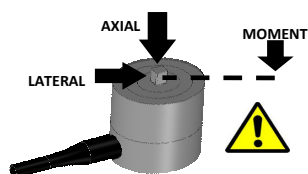

Per una corretta misura dovrebbero essere assenti sia le forze assiali, trasversali che il momento flettente. In loro presenza, non dovranno superare i valori indicati, da ridursi in presenza contemporanea di più sollecitazioni.

For correct measurement both axial and transverse forces and bending moment should be absent. In case of presence, they must not be greater than values indicated below, to be reduced in simultaneous presence of more solicitations.

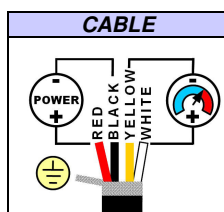
Collegamenti Elettrici Electrical Connections

Cavo schermato PVC 105°C, Ø5.2mm a 4 conduttori Ø0.35mm² stagnati. Schermo collegato al corpo del torsiometro.

PVC 105°C shielded cable, Ø5.2mm with 4 tinned Ø0.35mm² conductors. Shield connected to the body of the torque meter.

AEP transducers



Dasa-Rägister
EN ISO 9001:2015
IQ-1100-01



LAT N° 093
Calibration Centre
The products are NOT
covered by accreditation



Production Quality
Assurance Certified n°
TÜV CY 17 ATEX 0205891 Q

41126 Cognento (MODENA) Italy Via Bottego 33/A Tel: +39-(0)59-346441 Fax: +39-(0)59-346437 E-mail: aep@aep.it

Al fine di migliorare le prestazioni tecniche del prodotto, la società si riserva di apportare variazioni senza preavviso.
In order to improve the technical performances of the product, the company reserves the right to make any change without notice.