

**Measurement of: WEIGHT, FORCE, PRESSURE, DISPLACEMENT, TEMPERATURE  
TORQUE, ANGLE and SPEED.**



RISOLUZIONE STANDARD  
**± 100000 div**  
RESOLUTION STANDARD

ACCURATEZZA  
**≤ ± 0.01%**  
ACCURACY

VERSIONE K  
**± 300000 div**  
K VERSION

ACCURATEZZA  
**≤ ± 0.005%**  
ACCURACY

15  
Stabilità a  
lungo termine  
Long term  
high stability

CE RoHS

Smart

Alta Affidabilità  
High Reliability

"THE EVOLUTION OF THE SPECIES" : after more than 30 years of service in the various versions the new **MP2Plus** is born.

**MP2Plus** is a Professional Digital Laboratory Indicator with **1** (standard) or **2** (option) **inputs**, suitable for receiving signals from strain gauge sensors, transmitters with voltage or current output, PT100, potentiometer and ENCODER. Particularly suitable for both static and dynamic applications, for calibration and verification in metrology laboratories or industrial environments where it is necessary to make measurements of weight, force, pressure, torque, displacement and temperature.

To **FIT EVERY APPLICATION** the instrument can be configured and customized: the function keys F1, F2, F3 and F4 can be programmed for the function of interest such as: PEAK, HOLD, RELEASE, TX DATA DATALOG, DISCHARGE, ZOOM and **COUNTING**.

The instrument works with a resolution of  $\pm 100.000$  divisions and exceeds 0,005% accuracy thanks to an internal 24-bit Sigma-Delta AD converter and a measurement control system working at a frequency equal to the sampling frequency: this system provides a better suppression of interference caused by offset drift and connecting cables.

The sampling frequency can be set from 2,5 samples per second up to 4800 samples per second therefore the instrument meets the needs of applications that require a considerable speed of response.

Each input channels can be supplied in 6 different configurations:

- Version with **input for strain gauge transducers** with standard resolution of  $\pm 100.000$  div. suitable for working with load cells or force transducers with output  $\pm 2$  mV/V or  $\pm 3$  mV/V and 4 wires or 6 wires connection.
- Version with **voltage input** with standard resolution of  $\pm 100.000$  div. suitable for working with pressure, torque transmitters, etc ... with output  $\pm 10$  V or  $\pm 5$  V.
- Version with **current input** with a standard resolution of  $\pm 160.000$  div. suitable for working with pressure, torque transmitters, etc ... with output 4-20mA or 0-20mA with 2 or 3 wires connections.
- Version with **temperature input** for PT100 eligible to work in the range from -50 °C to + 250 °C with 0,1 °C resolution and accuracy  $\pm 1$  °C.
- Version with **incremental ENCODER input** suitable for working with linear or rotary encoders. Also you can define whether to measure angle, displacement or speed.
- Version with **POTENTIOMETER input** suitable for working with linear transducers or displacement.
- Version with **LVDT input** suitable for working with linear transducers or displacement.

**MP2Plus** has in the standard configuration:

- **4 DIGITAL INPUT** 24Vdc with function programmable.
- **5** programmable **SET POINT**.
- **4 RELAYS** type DPDT. The relays can be programmed, in combination of the setpoint, to create a simple automation or logics of intervention.
- A rear **USB** port to connect directly to a PC or Tablet.

As **OPTIONS** the instrument can be equipped with:

- **Additional input channel CH2** with a synchronization system that allows to acquire at the same instant the measurement of CH1 and CH2 channels. The refresh rate of the analog signals is equal to the frequency of acquisition of the respective channels in input.
- One or two programmable **Analog Outputs** by means of voltage ( $\pm 10V$ , 0-5V, 0-10V,  $\pm 5V$ ) or current (4-20mA) that can be associated to different channels or to the TOTAL (sum of two channels).
- A serial **RS232C** line to directly connect the device to a PC, PLC or a serial **PRINTER**. Moreover **MP2Plus** can be programmed to work as **REPEATER**.
- A serial **RS485** line with protocol MODBUS RTU normally used to connect multiple instruments in a same network to a PLC.
- **FIELDBUS** Communication selectable among: **DeviceNet**, **CANopen**, **Ethernet/IP**, **PROFIBUS**, **PROFINET** to be connected inside a standard PLC network.
- **WIRELESS** transmission designed to transmit measurements to other devices by radio at a distance up to 100m.
- A powerful **DATALOGGER** with non-volatile memory, which allows to store data at the maximum acquisition speed, synchronize recordings with an internal clock-calendar and eventually export data to a file using an USB stick in .csv file format that can be transferred directly to Microsoft Excel.

Other features and functions of importance are:

- Graphical, large and high resolution LCD display with backlit.
- Automatic **UNIT CONVERSIONS** in many specific units for each type of transducers.
- **MULTIMETER** function which displays the signal of the sensor directly in mV/V, V or mA.
- User selectable language : **ITALIAN or ENGLISH**.
- Function **ZERO** and **AUTOZERO** to reset automatically the measure if the measurement is below a set threshold.
- Function **COUNTING** to define the number of pieces on the scale.
- Function of **HOLD**, **PEAK**, programmable **FILTER**.
- Function of **DISCHARGE** in order to measure the amount of product discharged for example from a tank.
- Function **TOTAL** to perform the sum of channels CH1 and CH2.
- Function **KEY LOCK** to protect the instrument settings by unauthorized persons.
- Function **CLOCK-CALENDAR** (Option) with date and time.
- 24 columns **PRINTER** (Option) connected to the serial port through which it is possible to print the measuring points with the date and time and the data of the company that carried out the survey.
- **REPEATER** Function: The instrument can be configured to display (in the passive form as a slave unit) measurements from the RS232C serial port (for example from another **MP2Plus** - Master).
- In this case all the features enabled on the **MP2Plus** Slave will be active (Setpoint, USB, printer, logger etc). The **REPEATER** function is active for one channel.

For each input channel, you can calibrate the signal coming from the sensor in both the **POSITIVE RANGE** and in the **NEGATIVE RANGE** (Example in tension and compression) through 3 different modes:

- Calibration with **Full Scale**: characterization through the programming of the transducer full scale and sensitivity in both the positive and the negative range.
- Calibration for **POINTS**: linearity correction by programming 5 known points in both the positive and negative range.
- **Known Weight**: practice characterization (in the field) by imposing a known weight, pressure, torque to the sensor and calibrating the transducer output to this reference value.

To increase security the instrument has the ability to perform a **BACKUP** of all calibrations data so that you can recall them in case of accidental tampering.

**MP2Plus** can be accompanied by the PC program **MP Supervisor** (Option) which allows easy connection between the instrumento and the pc over USB and allows you to display graphs or export data to Microsoft Excel.





The program also allows you to download the data log either stored on the internal memory or on a USB stick and easily compare the measurements.

**Typical applications:**

- Automatic weighing systems and small dosages.
- Systems for monitoring levels of tanks, silos and hoppers.
- Integrated measurement systems on test benches and testing.
- Measurement systems integrated into automated processes.
- Control systems of industrial processes.
- Automatic Testing and Quality Control systems in production lines.
- Control measurements on board for material testing machines.
- Control measurements on springs, friction detection, breakout forces, leakage tests.
- Tests on protective and safety devices.





**STANDARD CONFIGURATION**



<b>INPUT</b>	<p><b>CH1</b>  <math>\pm 2</math> mV/V, <math>\pm 3</math> mV/V <math>\pm 5</math>, <math>\pm 10</math>V, 0-20 mA, 4-20 mA                  POTENTIOMETER</p>
--------------	---

<b>FUNCTION</b>	<p><b>POWER SUPPLY 220 Vac</b></p>  <p><b>NO External Power Supply</b></p>	 <p><b>USB 2.0</b></p>	<p>PEAK TOTAL DISCHARGE DIGITAL FILTER ZERO and AUTOZERO DIGITAL CALIBRATIONS UNIT CONVERSION</p>	<p><b>5 Set Point 4 RELAYS programmable</b></p>  <p><b>Can be used for:</b></p> <ul style="list-style-type: none"> <li>motors ON / OFF</li> <li>solenoid ON / OFF</li> </ul>	<p><b>4 Programmable Digital Inputs</b></p>  <p><b>Used for:</b></p> <ul style="list-style-type: none"> <li>Remote Function key</li> <li>PLC Commands</li> </ul>
-----------------	--	--	---	---	---

**ADDITIONAL OPTIONS**

<b>INPUT</b>	<p><b>CH2 OPTION</b>  <math>\pm 2</math> mV/V, <math>\pm 3</math> mV/V  <math>\pm 5</math> V, <math>\pm 10</math> V                  0-20 mA, 4-20 mA</p>	<p>POTENTIOMETER                  PT100 (temperature)                  incremental ENCODER                  LVDT</p>
--------------	---	--

<b>OPTION</b>	<p><b>SERIAL COMM:</b> RS232C, RS485 Modbus  <b>FIELDBUS:</b>                  DeviceNet, CANopen, PROFIBUS, PROFINET, EtherNet/IP</p>  <p><b>PLC</b> <b>PC</b></p> <p><b>PRINTER</b> <b>REPEATER</b></p> 	<p><b>ANALOG OUPUT N° 1</b></p> <p>Associated to CH1, CH2 or to TOTAL (CH1+CH2)</p> <p>The refresh rate of the analog signals is equal to the frequency of acquisition of the respective channels in input.</p>  <p><b>INVERTER</b> <b>PLC</b> <b>RECORDER</b></p>	<p><b>ANALOG OUPUT N° 2</b></p> <p>Associated to CH1, CH2 or to TOTAL (CH1+CH2)</p>	<p><b>Wireless DATA TRANSMISSION</b></p>  <p><b>PC</b> <b>Smartphone</b></p>
---------------	--	--	---	---

<b>OPTION</b>	<p><b>Data Logger</b></p> <p>+</p> <p><b>Internal CLOCK CALENDAR</b></p>	 <p>Front panel USB port to download data logger using a USB sticks and to bring data directly to a PC. File type : csv or txt</p>	<p><b>POWER SUPPLY</b></p> <p><b>115 Vac</b></p> <p><b>24 Vdc</b></p>	<p><b>APPLICATION SOFTWARE</b>  <b>MP Supervisor</b></p>  <p>Instrument Configuration                  Data Analysis                  DataLogger Management                  Graphics</p>
---------------	--	---	---	--

## TECHNICAL DATA

<b>STANDARD NUMBER OF CHANNELS</b>	1 (CH1)
ACCURACY	± 0,010 %
LINEARITY ERROR	± 0,010 %
INTERNAL DIVISIONS	24 bit
<b>INPUT CH1: STRAIN GAUGE TRANSDUCERS</b>	<b>± 2 mV/V and ± 3 mV/V</b> (max ± 3.5 mV/V)
RESOLUTION	± 100.000div
TRANSDUCERS POWER SUPPLY	5 Vdc switching (± 3 %)
TYPE OF CONNECTION	4 or 6 wires
TRANSDUCER RESISTANCE	from 100 Ω to 2000 Ω
TRANSDUCERS CONNECTED IN PARALLEL	For each channel: <b>4</b> to 350 Ω or <b>8</b> to 700 Ω
<b>INPUT CH1: VOLTAGE AMPLIFIED TRANSDUCERS</b>	<b>± 10 V and ± 5 V</b>
RESOLUTION	± 100.000 div
TRANSDUCERS POWER SUPPLY	20 Vdc (± 1 Vdc)
<b>INPUT CH1: CURRENT AMPLIFIED TRANSDUCERS</b>	<b>0-20 mA</b>   <b>4-20 mA</b>
RESOLUTION	+ 200.000 div   + 160.000 div
TRANSDUCERS POWER SUPPLY	20 Vdc (± 1 Vdc)
<b>INPUT CH1: POTENTIOMETER</b>	R min. 1 kΩ
POWER SUPPLY	5 Vdc
Unit Conversions for <b>WEIGHT</b> and <b>FORCE</b>	kg, t, N, daN, kN, MN, lb, klb
Unit Conversions for <b>PRESSURE</b>	bar, mbar, psi, MPa, kPa, Pa, mH <sub>2</sub> O, inH <sub>2</sub> O, kg/cm <sup>2</sup> mmHg, cmHg, inHg, atm
Unit Conversions for <b>TORQUE</b>	N·m, N·mm, kN·m, kg·m, g·cm, kg·mm, ft·lbf, in·lbf
Unit Conversions for <b>DISPLACEMENT</b>	mm, m, foot, inch, cm, dm, μm
<b>MULTIMETER FUNCTION</b>	Direct Display in mV/V, Volt or mA
BACKLIT GRAPHIC DISPLAY	128 x 64 dots
CHARACTER SIZE	~ 13 mm
ADJUSTING DISPLAY CONTRAST	YES
TRANSDUCER CALIBRATION	Both in the POSITIVE and NEGATIVE range
TYPE OF DIGITAL CALIBRATION	Full Scale, Point Interpolation, Known Weight
FIELD LINEARITATION	On 1 ... 5 measurement point
BACKUP AND RESTORE FUNCTION	Save and restore all configuration data
FUNCTION OF ZERO	100% (on all the measurement range)
FUNCTION OF AUTOZERO	With TIME and THRESHOLD programming
FUNCTION OF PEAK	POSITIVE and NEGATIVE
FUNCTION OF DISCHARGE	YES
FUNCTION OF COUNTING	YES
FUNCTION OF KEY BLOCK	Enabled through a Password
FUNCTION OF TOTAL (CH1+CH2)	YES
PROGRAMMABLE RESOLUTION	1 ... 100
DIGITAL FILTER	0 ... 5
PROGRAMMABLE DECIMAL POSITION POINT	0 ... 5
PROGRAMMABLE CONVERSION RATE	from 2.5 to 4800 samples for second
INSTRUMENT LANGUAGE	ITALIAN and ENGLISH
FUNCTION KEYS PROGRAMMABLE IN CONFIGURATION	F1 – F2 – F3 – F4
SET POINT PROGRAMMABLE	5
PROGRAMMABLE DIGITAL INPUTS	4
RELAY OUTPUT (DPDT form)	4
MAX TENSION	220 Vdc – 250 Vac
MAX CURRENT	2 A
MAX POWER	60 W – 62,5 VA
<b>Rear Panel USB output, Connector type B</b>	<b>Max Cable Length 3.5 m</b>
NOMINAL WORKING TEMPERATURE	0... +50 °C
MAX WORKING TEMPERATURE	0... +50 °C
STORAGE TEMPERATURE	-20... +70 °C
TEMPERATURE EFFECTS on zero (10°C variation)	± 0,005 %
TEMPERATURE EFFECTS on full scale (10°C)	± 0,005 %
POWER SUPPLY	230 Vac +/-10 %
FREQUENCY	50/60 Hz
EXTERNAL PROTECTION FUSE	250mA / 250 V
MAX. POWER REQUIRED	10 VA
PANEL MOUNTING CASE	DIN 43700
CASE MATERIAL	NORYL UL94 V-O
FRONT AND REAR PANEL MATERIAL	UL94 V-2
PROTECTION CLASS (EN 60529)	IP40 (only front panel)
DEGREE OF ENVIRONMENTAL CONT.	1
DIMENSIONS (H x L x D)	72 x 144 x 150 mm
DRILLING TEMPLATE (A x L)	68 x 138 mm
WEIGHT	~ 0,8 kg

**OPTIONS**

**INPUTS**

<p><b>K VERSION</b>                  ACCURACY                  LINEARITY ERROR  <b>STRAIN GAUGE INPUT</b>                  RESOLUTION                  TRANSDUCERS POWER SUPPLY                  TRANSDUCER RESISTANCE</p>	<p>Only for Strain Gauge Inputs  <math>\leq \pm 0.005\%</math>  <math>\leq \pm 0.005\%</math>  <math>\pm 2 \text{ mV/V}</math>  <math>\pm 300.000 \text{ div}</math>                  5 Vdc switching (<math>\pm 3\%</math>)  <math>n^\circ 1 (350 \Omega \text{ or } 700 \Omega)</math></p>
<p><b>INPUT CH2: STRAIN GAUGE</b>                  RESOLUTION                  TRANSDUCERS POWER SUPPLY                  TYPE OF CONNECTION                  TRANSDUCER RESISTANCE                  MAX NUMBER OF TRANSDUCERS IN PARALLEL</p>	<p><math>\pm 2 \text{ mV/V}</math> (max <math>\pm 3,5 \text{ mV/V}</math>)  <math>\pm 100.000 \text{ div}</math>                  5Vdc switching (<math>\pm 3\%</math>)                  4 or 6 wires                  from 100 <math>\Omega</math> to 2000 <math>\Omega</math>                  For each channel: <b>4</b> to 350 <math>\Omega</math> or <b>8</b> to 700 <math>\Omega</math></p>
<p><b>INPUT CH2 VOLTAGE AMPLIFIED TRANSDUCERS</b>                  RESOLUTION                  TRANSDUCERS POWER SUPPLY</p>	<p><math>\pm 10 \text{ V}</math> e <math>\pm 5 \text{ V}</math>  <math>\pm 100.000 \text{ div}</math>                  20 Vdc</p>
<p><b>INPUT CH2 : CURRENT AMPLIFIED TRANSDUCERS</b>                  RESOLUTION                  TRANSDUCERS POWER SUPPLY</p>	<p><b>0-20 mA</b>   <b>4-20 mA</b>  <math>+200.000 \text{ div}</math>   <math>+160.000 \text{ div}</math>                  20 Vdc</p>
<p><b>INPUT CH2 : TEMPERATURE</b>                  ACCURACY                  RESOLUTION                  UNIT CONVERSIONS</p>	<p><b>PT100 2 fili</b> (range -50 +250 <math>^\circ\text{C}</math>)  <math>\pm 1 \text{ }^\circ\text{C}</math>  <math>\pm 0,1 \text{ }^\circ\text{C}</math>  <math>^\circ\text{C}, ^\circ\text{F}</math></p>
<p><b>INPUT CH2 : incremental ENCODER</b>                  TYPE OF INPUT                   Unit Conversions for <b>DISPLACEMENT</b>                  Unit Conversions for <b>ANGLE</b>                  Unit Conversions for <b>SPEED</b></p>	<p>linear and rotary encoders                  RS422 line driver power supply a 5Vdc (A+,A-,B+,B-)                  5Vdc Open Collector (A,B)                  TTL (A,B)                  m, dm, cm, mm, <math>\mu\text{m}</math>, foot, inch  <math>^\circ</math> (degrees)                  mm//min, m/min, ft/min, in/min, mm/s, m/s, ft/s, in/s, rpm, Hz</p>
<p><b>INPUT CH2: POTENTIOMETER</b>                  POWER SUPPLY</p>	<p>R min. 1 k<math>\Omega</math>                  5 Vdc</p>
<p><b>INPUT CH2: LVDT</b>                  POWER SUPPLY                  FREQUENCY                  SENSIBILITY                  Unit Conversions for <b>DISPLACEMENT</b></p>	<p>5 VRMS                  5 kHz                  from 20 to 100 mV/V/mm                  m, dm, cm, mm, <math>\mu\text{m}</math>, foot, inch</p>

**COMMUNICATIONS**

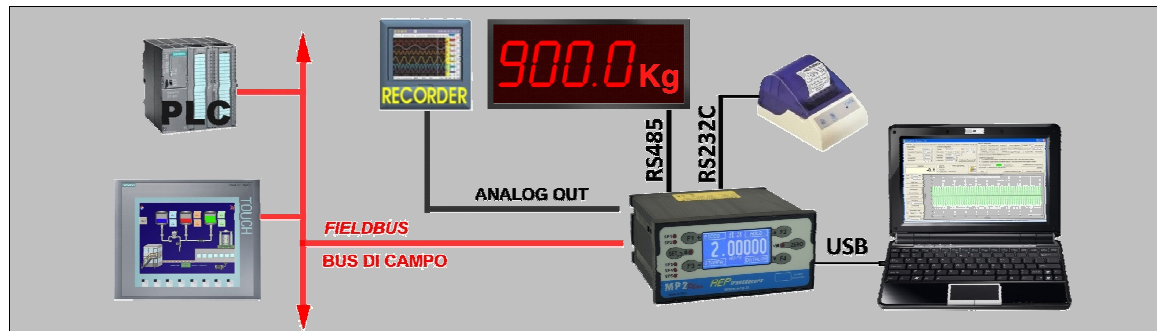

The USB, RS232C, FIELDBUS and RS485 are **INDEPENDENT** so it is possible to connect many devices at the same time like PC, PLC, 24 columns serial PRINTER, remote analog recorder, large display, Operator Panel and so on.

<p><b>RS232C SERIAL LINE</b>  <b>RS485 MODBUS RTU</b> (max 32 in multipoint)  <b>PRINTER</b>                  On the report is it possible to print up to 3 header lines with the company data. A measurement point will be printed by pressing the key PRINT or using a remote digital command. You can print on both paper and adhesive labels.</p>	<p>MAX cable Lenght 13 m                  MAX cable Lenght 1000 m                  24 columns (RS232C)</p>
<p><b>Analog Outputs</b>                  Current Output                  Voltage Output (max 20mA – RL min: 1k<math>\Omega</math>)</p>	<p>1 or 2 outputs independent                  4-20 mA                  0-5 V, 0-10 V, <math>\pm 10 \text{ V}</math>, <math>\pm 5 \text{ V}</math></p>
<p><b>WIRELESS transmission</b>                  Max distance in free space</p>	<p>433 MHz                  100 m</p>
<p><b>FIELDBUS</b></p>	<p><b>DeviceNet, CANopen, Ethernet/IP, PROFIBUS, PROFINET</b></p>

**DATA LOGGER**

**DATA LOGGER** allows you to store the measurements and to keep them in internal memory even if you turn off the instrument. The logging can be done in **AUTO** mode or **MANUAL** mode. The **AUTO** mode records the measurements at regular time intervals for a programmable duration. The time interval between two measurement points can be varied from the maximum speed of reading (4,8 kHz) up to recording every 24 hours. The **MANUAL** mode allows the operator to decide when to record the measurements on memory. The command can be given either via a button on the front panel or via a digital input. All data can be displayed on the display, downloaded through the powerful **MP Supervisor** software or exported to external Flash Memory (USB stick) for charting, data processing on Microsoft Excel, press reports etc ...

<b>DATA LOGGER (INTERNAL)</b> Max Storing Points	<b>DATA LOGGER (INTERNAL)</b> Max Storing Points
MAX PROGRAMMABLE TIME CLOCK - CALENDAR	MAX PROGRAMMABLE TIME CLOCK - CALENDAR
<b>Front Panel USB</b> connector (type A) that allows you to save or export the recorded measurements directly on a USB stick, for faster portability of the measures on PC. It is possible to export the data in .TXT or .CSV files to be easily imported in softwares such as Microsoft Excel.	

<b>OUTPUT RELAYS DPDT type</b>	5° Relay
<b>POWER SUPPLY</b>	115 Vac or 24 Vdc

**COMPONENTS SUPPLIED**



Mounting Brackets



DB9 Male Connector for transducer



CD with Manual and USB Driver

**COMPONENTS IN OPTION (purchased separately)**



USB Cable



RS232C Serial Cable



DB9 Male Connector for transducers



Desktop 24 columns printer

**ELECTRICAL CONNECTION**

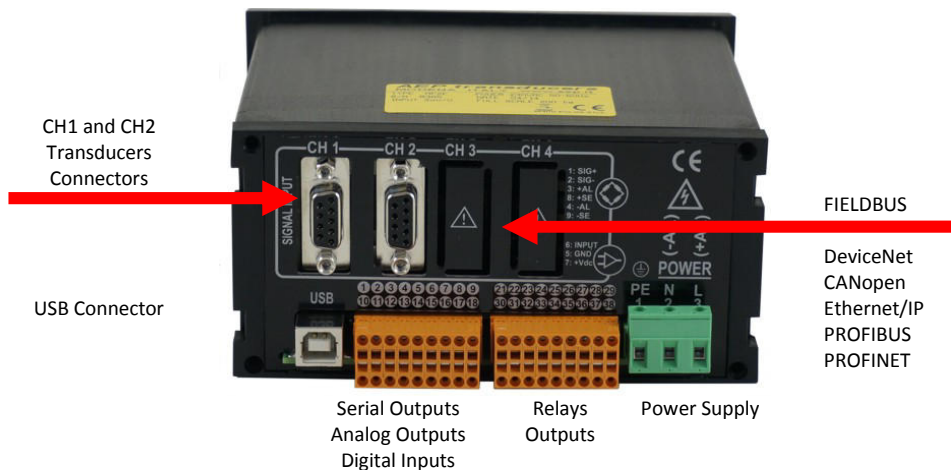

### MP Supervisor (Option)

A dedicated program that allows an immediate interfacing through the USB port with the MP2Plus and allows you to view graphs, export data to Microsoft Excel directly from the PC and set all configuration parameters. The program also allows you to download a data log carried out using the internal memory or the USB Flash Memory and display the respective curves of acquisition.

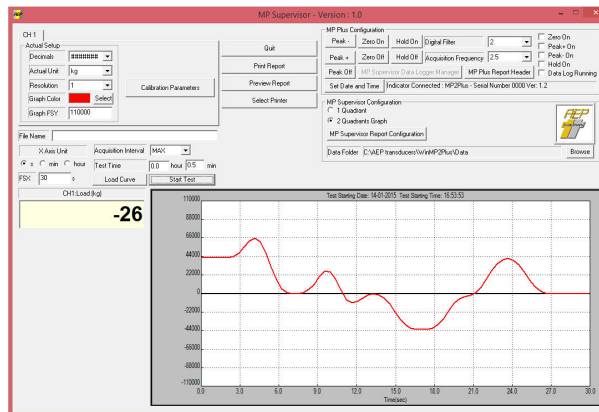

### Quick Analyzer (Option)

Quick Analyzer is a powerful software that allows you to connect efficiently and easily with all of AEP instrumentation transducers with RS232 or USB serial communication channels. Through a simple configuration of the channels and to an effective setting of the sensor characteristics to which instruments are connected, you can check the communication status, run tests and save the curves obtained graphs, calculate the principal test results, print the relevant certificates and export the measurements in Excel. Dedicated to recording and graphical analysis of up to 16 different instruments for measurements of force, weight, pressure, torque and displacement.

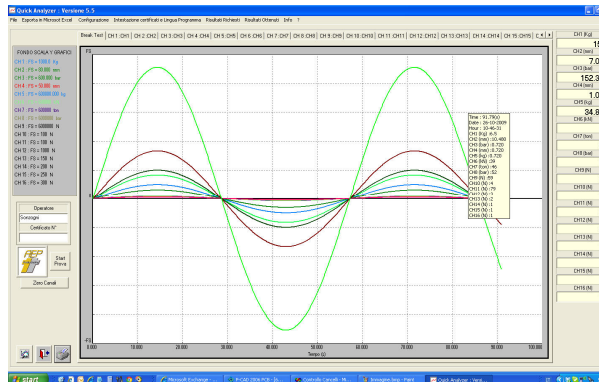

The test curves obtained can be displayed simultaneously in a single graph with respect to time or to other chosen channel, with different colors and can be set, for an easier recognition of the same, or individually (with respect to time) for easy analysis of details of a single sensor connected.

### Typical APPLICATION

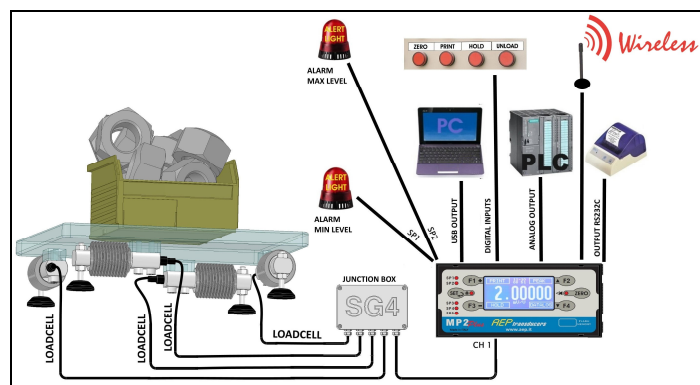

Weighing system with **COUNTING** function.

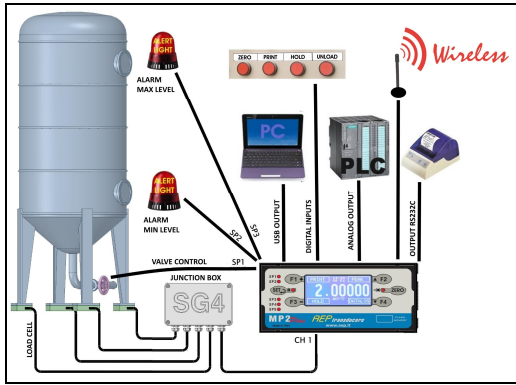

WEIGHING system of a silo.

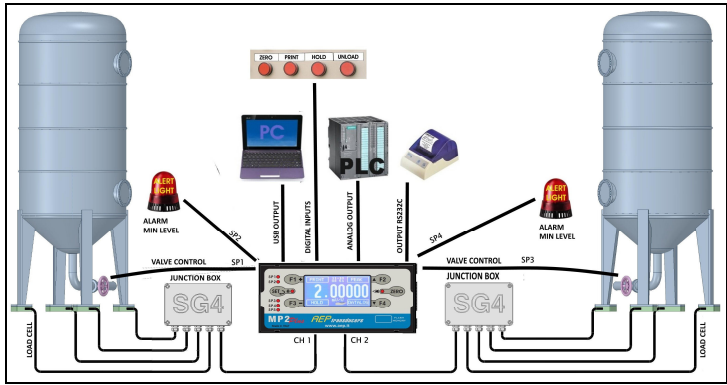

WEIGHING system of 2 silos.

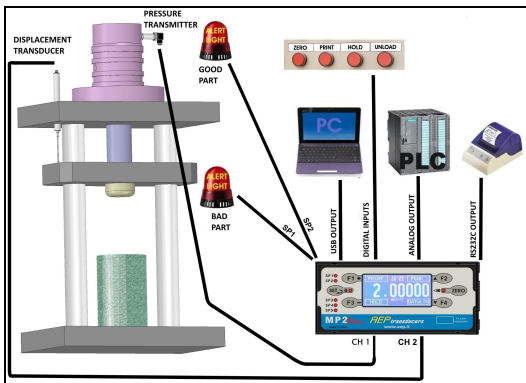

Measurement system of hydraulic or pneumatic press with direct control of PRESSURE and DISPLACEMENT

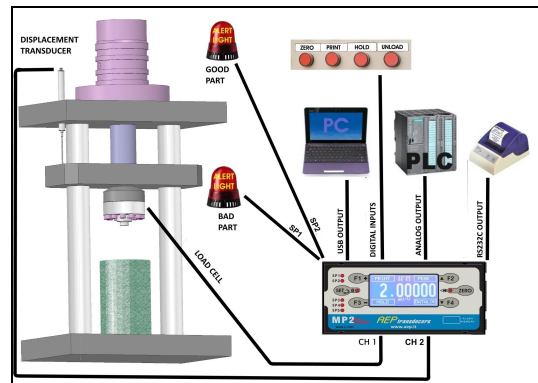

Measurement system on the press with direct control of FORCE and DISPLACEMENT

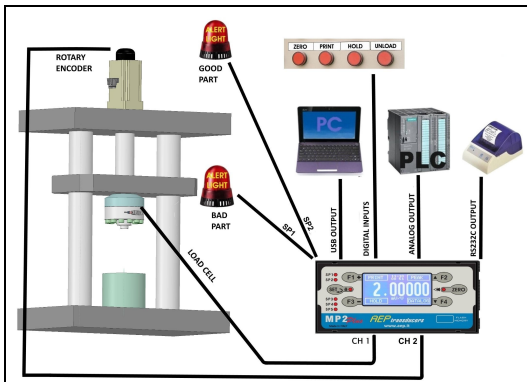

Measurement system on the press with direct control of FORCE and DISPLACEMENT (ENCODER)

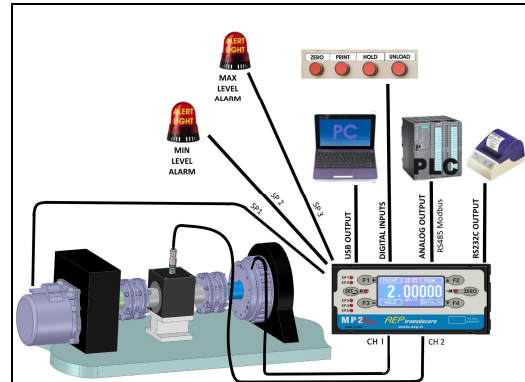

Measuring system on the test bench brake torque control and temperature developed by the brake

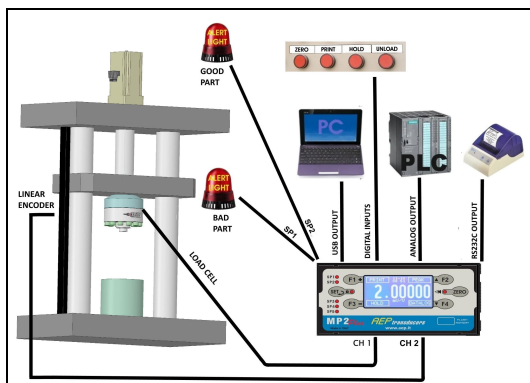

Measurement system on the press with direct control of FORCE and DISPLACEMENT (ENCODER)



Wireless Transmission



**Dimensions (mm)**

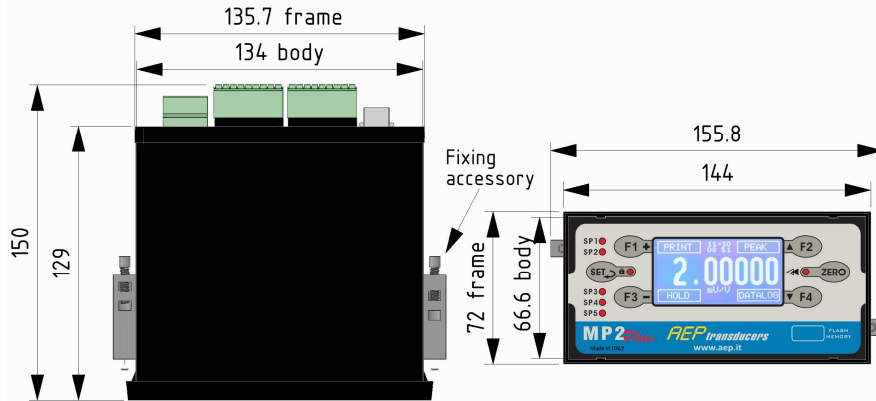

**MOUNTING PANEL APPLICATION**



**PURCHASE CODES**

MP2P	X	X	XXX	XX	X	XX	X	X
	<b>K</b> Version ±300.000	<b>2</b> 2 channels	<b>230</b> 230 Vac	<b>A1</b> 1 Output	<b>S</b> RS458 Modbus RS232C, Printer	<b>R5</b> 5 Relè	<b>D</b> Data logger Clock Calendar	<b>W</b> Wireless Transmission
			<b>115</b> 115Vac	<b>A2</b> 2 Outputs			<b>F</b> Data logger, Clock Calendar USB Flash Memory	<b>N</b> DeviceNet
			<b>24</b> 24Vdc					<b>C</b> CANopen
								<b>B</b> PROFIBUS
								<b>P</b> PROFINET
								<b>E</b> EtherNet/IP

**Example: MP2P230** (MP2Plus – power supply 230Vac – basic version)

**Example: MP2P224A2S** (MP2Plus 2 Channels – power supply 24Vdc + 2 analog outputs + Serial output)

**Example: MP2P2115SFC** (MP2Plus 2 Channels – power supply 115Vac + Serial output + DATALOGGER+ USB Flash Memory + CANopen)



**ALWAYS SPECIFY** in the purchase order how to configure the input channels.  
After the sale, the inputs **can not be changed** by the customer.

**Example of channel configuration CH1:** 2 mV/V, 4-20 mA, ± 10 V

**Example of channel configuration CH2:** 2 mV/V, 4-20 mA, ± 10 V, PT100, ENCODER, POTENTIOMETER, LVDT



LAT N° 093  
**Calibration Centre**  
The products are NOT covered by accreditation



**Production Quality Assurance Certified n°**  
TÜV CY 17 ATEX 0205891 Q

41126 Cognento (MODENA) Italy Via Bottego 33/A Tel: +39-(0)59-346441 Fax: +39-(0)59-346437 E-mail: aep@aep.it

Al fine di migliorare le prestazioni tecniche del prodotto, la società si riserva di apportare variazioni senza preavviso.  
In order to improve the technical performances of the product, the company reserves the right to make any change without notice.