

**Measurement of: WEIGHT, FORCE, PRESSURE, DISPLACEMENT, TEMPERATURE  
TORQUE, ANGLE and SPEED.**



RISOLUZIONE STANDARD  
**± 100000 div**  
RESOLUTION STANDARD

ACCURATEZZA  
**≤ ± 0.005%**  
ACCURACY

Stabilità a lungo termine  
Long term high stability

Alta Affidabilità  
High Reliability

CE RoHS

USB 2.0

Smart

Data Logger

**"THE EVOLUTION OF THE SPECIES"**: after more than 30 years of service in the various versions the new **MP6Plus** is born.

**MP6Plus** is a Professional Digital Laboratory Indicator with **1, 2, 3, or 4 inputs**, suitable for receiving signals from strain gauge sensors, transmitters with voltage or current output, PT100, potentiometers and ENCODERS.

Particularly suitable for both static and dynamic applications, for calibration and verification in metrology laboratories or industrial environments where it is necessary to make measurements of weight, force, pressure, torque, displacement and temperature in a synchronized manner.

To **FIT EVERY APPLICATION** the instrument can be configured and customized: the function keys F1, F2, F3 and F4 can be programmed for the function of interest such as: PEAK, HOLD, RELEASE, TX DATA DATALOG, DISCHARGE, ZOOM.

**MP6Plus** allows you to enable and disable each channel and using the **ZOOM** function it is possible to display only the channel of interest in full screen.

The instrument works with a resolution of  $\pm 100.000$  divisions and exceeds 0,005% accuracy due to an internal 24-bit Sigma-Delta AD converter and a measurement control system working at a frequency equal to the sampling frequency: this system provides a better suppression of interference caused by offset drift and connecting cables.

The sampling frequency (common to all channels) can be set from 2.5 samples per second up to 4800 samples per second therefore the instrument meets the needs of applications that require a considerable speed of response.

Each input channels can be supplied in 4 different configurations:

- Version with **input for strain gauge transducers** with standard resolution of  $\pm 100.000$  div. suitable for working with load cells or force transducers with output  $\pm 2\text{mV/V}$  or  $\pm 3\text{mV/V}$  and 4 wires or 6 wires connection.
- Version with **voltage input** with standard resolution of  $\pm 100.000$  div. suitable for working with pressure, torque transmitters, etc ... with output  $\pm 10\text{ V}$  or  $\pm 5\text{ V}$ .
- Version with **current input** with a standard resolution of  $\pm 160.000$  div. suitable for working with pressure, torque transmitters, etc ... with output 4-20mA or 0-20mA and 2- and 3-wires.
- Version with **temperature input** for PT100 eligible to work in the range from  $-50\text{ °C}$  to  $+250\text{ °C}$  with  $0.1\text{ °C}$  resolution and accuracy  $\pm 1\text{ °C}$ .
- Version with **incremental ENCODER input** suitable for working with linear or rotary encoders. Also you can define whether to measure angle, displacement or speed.
- Version with **POTENTIOMETER input** suitable for working with linear transducers or displacement.

The instrument is equipped with a rear **USB** port to connect directly to a PC or Tablet.

As **OPTIONS**, the instrument can be equipped with:

- **Additional input channels CH2, CH3 and CH4** with a synchronization system that allows to acquire at the same instant the measurement of all channels.
- One, two, three or four **Analog Outputs** programmable as voltage ( $\pm 10$  V, 0-5 V, 0-10 V,  $\pm 5$  V) or current (4-20 mA, 0-20 mA, 0-24 mA) that can be associated to different channels or to the **TOTAL** (sum of two or more channels). The refresh rate of the analog signals is equal to the frequency of acquisition of the respective channels in input.
- A serial **RS232C** line to directly connect the device to a PC, PLC or a serial **PRINTER**.
- 4 programmable **DIGITAL INPUTS** 24Vdc.
- A serial **RS485** line with protocol MODBUS RTU normally used to connect multiple instruments in a same network to a PLC.
- **WIRELESS** transmission designed to transmit measurements to other devices by radio at a distance up to 100m.
- A powerful **DATALOGGER** with non-volatile memory, which allows to store data at the maximum acquisition speed, synchronize recordings with an internal clock-calendar and eventually export data to a file using an USB stick in .csv file format that can be transferred directly to Microsoft Excel.

Other features and functions of importance are:

- Graphical, large and high-resolution LCD display with backlit.
- Automatic **UNIT CONVERSIONS** in many specific units for each type of transducers.
- **MULTIMETER** function which displays the signal of the sensor directly in mV/V, V or mA.
- User selectable language: **ITALIAN or ENGLISH**.
- Function **ZERO** and **AUTOZERO** to reset automatically the measure if the measurement is below a set threshold.
- Function of **HOLD, PEAK**, programmable **FILTER**.
- Function of **DISCHARGE** in order to measure the amount of product discharged for example from a tank.
- Function **TOTAL** to perform the sum of the channels.
- Function **KEY LOCK** to protect the instrument settings by unauthorized persons.
- Function **CLOCK-CALENDAR** (Option) with date and time.
- 24 columns **PRINTER** (option) connected to the serial port through which it is possible to print the measuring points with the date and time and the data of the company that carried out the survey.

For each input channel, you can calibrate the signal coming from the sensor both in the **POSITIVE RANGE** and in the **NEGATIVE RANGE** (Example in tension and compression) through 3 different modes:

- Calibration with **Full Scale**: characterization through the programming of the transducer full scale and sensitivity in both the positive and negative range.
- Calibration for **POINTS**: linearity correction by programming 5 known points in both the positive and negative range.
- **Known Weight**: practice characterization (in the field) by imposing a known weight, pressure, torque to the sensor and calibrating the transducer output to this reference value.

To increase security the instrument has the ability to perform a **BACKUP** of all calibrations data so that you can recall them in case of accidental tampering.

**MP6Plus** may be accompanied by various applications and analysis software to perform calibrations for: PRESSURE FORCE and TORQUE measurements.

**MP6Plus** can be accompanied by the PC program **MP Supervisor** (Option) which allows easy connection between the instrument and the pc over USB and allows you to display graphs or export data to Microsoft Excel.

The program also allows you to download the data log either stored on the internal memory or on a USB stick and easily compare the measurements.

#### **Typical applications:**

Calibration of reference machines: force, pressure and torque.

Calibration of materials testing machines.

Calibration of test benches and testing machine.

Calibration of transducers, pressure transmitters and pressure switches.

Calibration of load cells, force transducers and dynamometers.

Calibration of torque wrenches, snap or direct reading screwdrivers.



Audits between laboratories for the verification of measurement uncertainties.

Audit to perform metrological confirmations.

Audit for interlaboratory comparisons.







Quality control in production lines.  
 Quality Control in Calibration and Testing Laboratories.  
 Tests on materials such as springs, friction detection, breakout forces.  
 Tests on protective devices and safety.  
 Monitoring over time of mechanical quantities.



## STANDARD CONFIGURATION

<b>INPUT</b>	<b>CH1</b> $\pm 2$ mV/V, $\pm 3$ mV/V $\pm 5$ V, $\pm 10$ V 0-20 mA, 4-20 mA		
<b>FUNCTION</b>	<b>Power Supply:</b> <b>220 Vac</b>	  <b>USB 2.0</b> 	PEAK, TOTAL, DISCHARGE, DIGITAL FILTER ZERO and AUTOZERO DIGITAL CALIBRATIONS UNIT CONVERSION

## ADDITIONAL OPTIONS

<b>INPUT</b>	<b>CH2 – CH3 – CH4 OPTIONS</b> $\pm 2$ mV/V, $\pm 3$ mV/V $\pm 10$ V, $\pm 5$ V 4-20 mA, 0-20 mA POTENTIOMETER		*PT100 (temperature) *ENCODER incremental  * only for channels CH2 and CH4
--------------	--	--	---

<b>OPTION</b>	RS232C RS485 MODBUS  PRINTER 	From 1 to 4 <b>ANALOG OUPUTS</b> Associated with channels CH1, CH2, CH3, CH4 or TOTAL The refresh rate of the analog signals is equal to the frequency of acquisition of the respective channels in input. 	<b>4 Programmable Digital Inputs</b>  Used for: <ul style="list-style-type: none"> <li>• Remote Function key</li> <li>• PLC Commands</li> </ul>	 <b>DATA TRANSMISSION</b> 
---------------	---	--	--	--

<b>OPTION</b>	 + Internal CLOCK and CALENDAR	 Front panel USB port to download data logger using a USB sticks and to bring data directly to a PC. File type : CSV or TXT	<b>Power Supply:</b> <b>115 Vac</b> <b>24 Vdc</b>	<b>HANDLE</b> 
---------------	---	--	---	--

## TECHNICAL DATA

<b>STANDARD NUMBER OF CHANNELS</b>	1 (CH1)
ACCURACY	≤± 0,005 %
LINEARITY ERROR	≤± 0,005 %
INTERNAL DIVISIONS	24 bit
<b>CH1 INPUT: STRAIN GAUGE TRANSDUCERS</b>	<b>± 2 mV/V and ± 3 mV/V</b> (max ± 3,5 mV/V)
RESOLUTION	± 100.000 div
TRANSDUCERS POWER SUPPLY	5 Vdc switching (± 3 %)
TYPE OF CONNECTION	4 or 6 wires
TRANSDUCER RESISTANCE	from 100 Ω to 2000 Ω
<b>CH1 INPUT: VOLTAGE AMPLIFIED TRANSDUCERS</b>	<b>± 10 V and ± 5 V</b>
RESOLUTION	± 100.000 div
TRANSDUCERS POWER SUPPLY	20 Vdc (± 1 Vdc)
<b>CH1 INPUT: CURRENT AMPLIFIED TRANSDUCERS</b>	<b>0-20 mA   4-20 mA</b>
RESOLUTION	+200.000 div   +160.000 div
TRANSDUCERS POWER SUPPLY	20 Vdc (± 1 Vdc)
<b>CH1 INPUT: POTENTIOMETER</b>	R min. 1 kΩ
POWER SUPPLY	5 Vdc
Unit Conversions for <b>WEIGHT</b> and <b>FORCE</b>	Kg, t, N, daN, kN, MN, lb, klb
Unit Conversions for <b>PRESSURE</b>	bar, mbar, psi, MPa, kPa, Pa, mH <sub>2</sub> O inH <sub>2</sub> O kg/cm <sup>2</sup> , mmHg, cmHg, inHg, atm
Unit Conversions for <b>TORQUE</b>	N-m, N-mm, kN-m, kg-m, g-cm, kg-mm, ft-lbf, in-lbf
Unit Conversions for <b>DISPLACEMENT</b>	mm, m, foot, inch, cm, dm, μm
<b>MULTIMETER FUNCTION</b>	Direct Display in mV/V, Volt o mA
BACKLIT GRAPHIC DISPLAY	128 x 64 dots
CHARACTER SIZE	~ 13 mm
ADJUSTING DISPLAY CONTRAST	YES
TRANSDUCER CALIBRATION	Both in the POSITIVE and NEGATIVE range
TYPE OF DIGITAL CALIBRATION	Full Scale, Point Interpolation, Known Weight
FIELD LINEARITATION	On 1 ... 5 measurement point
BACKUP AND RESTORE FUNCTION	Save and restore all configuration data
FUNCTION OF ZERO	100 % (on all the measurement range)
FUNCTION OF AUTOZERO	With TIME and THRESHOLD programming
FUNCTION OF PEAK	POSITIVE and NEGATIVE
FUNCTION OF DISCHARGE	YES
FUNCTION OF KEY BLOCK	Enabled through a Password
FUNCTION OF TOTAL (on all enabled channels)	YES
PROGRAMMABLE RESOLUTION	1 ... 100
DIGITAL FILTER	0 ... 5
PROGRAMMABLE DECIMAL POSITION POINT	0 ... 5
PROGRAMMABLE CONVERSION RATE	from 2,5 to 4800 samples for second
INSTRUMENT LANGUAGE	ITALIAN and ENGLISH
FUNCTION KEYS programmable in configuration	F1 – F2 – F3 – F4
<b>Rear USB output, Connector type B</b>	Max Cable Length 3,5 m
NOMINAL WORKING TEMPERATURE	0... +50 °C
MAX WORKING TEMPERATURE	0... +50 °C
STORAGE TEMPERATURE	-20... +70 °C
TEMPERATURE EFFECTS on the measurements	
a) on zero (10°C variation)	≤± 0,005 %
b) on full scale (10°C variation)	≤± 0,005 %
POWER SUPPLY	230 Vac ± 10 %
FREQUENCY	50/60 Hz
EXTERNAL PROTECTION FUSE	250 mA / 250 V
MAX. POWER REQUIRED	10 VA
CASE MATERIAL	Powder coated ALUMINIUM container
PROTECTION CLASS (EN 60529)	IP40
DEGREE OF ENVIRONMENTAL CONT.	1
WEIGHT	~ 0,8 kg

## OPTIONS

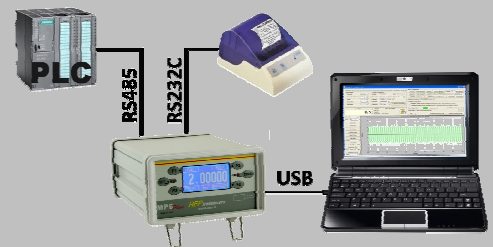
<b>INPUT CH2-CH3-CH4: STRAIN GAUGE TRANSDUCERS</b> RESOLUTION TRANSDUCERS POWER SUPPLY TYPE OF CONNECTION TRANSDUCER RESISTANCE	$\pm 2 \text{ mV/V}$ and $\pm 3 \text{ mV/V}$ (max $\pm 3,5 \text{ mV/V}$ ) $\pm 100.000 \text{ div}$ 5 Vdc switching ( $\pm 3 \%$ ) 4 or 6 wires from $100 \Omega$ to $2000 \Omega$						
<b>INPUT CH2 – CH3 - CH4: VOLTAGE AMPLIFIED</b> TRANSDUCERS RESOLUTION TRANSDUCERS POWER SUPPLY	$\pm 10 \text{ V e } \pm 5 \text{ V}$ $\pm 100.000 \text{ div}$ 20 Vdc						
<b>INPUT CH2 – CH3 - CH4: CURRENT AMPLIFIED</b> TRANSDUCERS RESOLUTION TRANSDUCERS POWER SUPPLY	<table style="width: 100%; border-collapse: collapse;"> <tr> <td style="width: 50%; text-align: center;"><b>0-20 mA</b></td> <td style="width: 50%; text-align: center;"><b>4-20 mA</b></td> </tr> <tr> <td style="text-align: center;">+200.000 div</td> <td style="text-align: center;">+160.000 div</td> </tr> <tr> <td colspan="2" style="text-align: center;">20 Vdc</td> </tr> </table>	<b>0-20 mA</b>	<b>4-20 mA</b>	+200.000 div	+160.000 div	20 Vdc	
<b>0-20 mA</b>	<b>4-20 mA</b>						
+200.000 div	+160.000 div						
20 Vdc							
<b>INPUT CH2 – CH3 - CH4: POTENTIOMETER</b> POWER SUPPLY	R min. $1 \text{ k}\Omega$ 5 Vdc						
<b>INPUT CH2 – CH4: TEMPERATURE</b> ACCURACY RESOLUTION UNITS	<b>PT100</b> 2 wires (range $-50$ $+250 \text{ }^\circ\text{C}$ ) $\pm 1 \text{ }^\circ\text{C}$ $\pm 0,1 \text{ }^\circ\text{C}$ $^\circ\text{C}, \text{ }^\circ\text{F}$						
<b>INPUT CH2 – CH4: incremental ENCODER</b> TYPE OF INPUT  Unit Conversions for <b>DISPLACEMENT</b> Unit Conversions for <b>ANGLE</b> Unit Conversions for <b>SPEED</b>	linear and rotary encoders RS422 line driver alimentazione a 5Vdc (A+,A-,B+,B-) 5Vdc Open Collector (A,B) TTL (A,B) m, dm, cm, mm, $\mu\text{m}$ , foot, inch $^\circ$ (degrees) mm/min, m/min, ft/min, in/min, mm/s, m/s, ft/s, in/s, rpm, Hz						
<b>RS232C SERIAL output</b> <b>RS485 MODBUS RTU</b> (max 32 in multipoint) <b>PRINTER output</b>  	MAX cable Length 13 m MAX cable Length 1000 m 24 columns (RS232C)  The USB, RS232 and RS485 are <b>INDEPENDENT</b> so it is possible to connect at the same time a PC, a PLC and a 24 columns serial printer.  On the report is it possible to print up to 3 header lines with the company data. A measurement point will be printed by pressing the key PRINT or using a remote digital command. You can print on both paper and adhesive labels.						
<b>Analog Outputs</b> Current Output Voltage Output (max 20mA – RL min: $1\text{k}\Omega$ )	1, 2, 3 or 4 independent outputs 0-20 mA, 4-20 mA, 0-24 mA 0-5 V, 0-10 V, $\pm 10 \text{ V}$ , $\pm 5 \text{ V}$						
<b>DIGITAL INPUTS</b> with programmable function	4						
<b>WIRELESS transmission – only version with up to 2 channels</b> Max distance in free space	433 MHz 100 m						
<b>DATA LOGGER</b> allows you to store the measurements and to keep them in internal memory even if you turn off the instrument. The logging can be done in <b>AUTO</b> mode or <b>MANUAL</b> mode. The <b>AUTO</b> mode records the measurements at regular intervals for a programmable time. The time interval between two measurements points can be varied from the maximum speed of reading (4,8 kHz) up to recording every 24 hours. The <b>MANUAL</b> mode allows the operator to decide when to record the measurements on memory. The command can be given either via a button on the front panel or via a digital input. All data can be subsequently displayed on the display, downloaded through the powerful software <b>MP Supervisor</b> or exported to external Flash Memory (USB stick) for charting, data processing on Microsoft Excel, press reports etc ...							
<b>DATA LOGGER</b> Max Storing Points	1 channel enabled: max. 130.000 2 channels enabled: max. 65.000 3 channels enabled: max. 32.000 4 channels enabled: max. 43.000 4 channels enabled +TOTAL: max. 26.000						
MAX PROGRAMMABLE TIME CLOCK - CALENDAR	100 days Year, Month, Day, Hour, Minute, Seconds						
<b>POWER SUPPLY</b>	115 Vac or 24 Vdc						

**COMPONENTS SUPPLIED**



Power supply cable



DB9 Male Connector for transducer

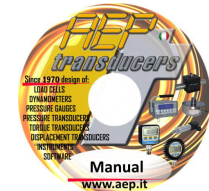

CD with Manual and USB Driver

**COMPONENTS IN OPTION (purchased separately)**

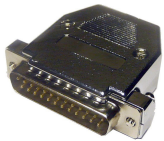

DB25 Male Connector for Input /Output



USB Cable



RS232C serial cable

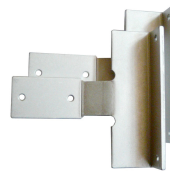

two brackets for panel mounting



Desktop 24 columns printer



DB9 Male Connector for transducers



Calibration Report ACCREDIA certificate (MP6+Transducers)

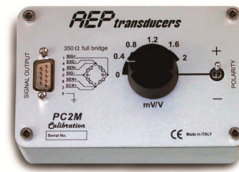

Signal Calibration in mV/V



Carrying case

**ELECTRICAL CONNECTION**



- ① Power supply.
- ② Fuse.
- ③ Interruttore generale.
- ④ USB output.
- ⑤ Serial outputs, analog Outputs, digital inputs.
- ⑥ Input channel CH1 standard.
- ⑦ Input channel CH2 option.
- ⑧ Input channel CH3 option.
- ⑨ Input channel CH4 option.



## APPLICAZIONI SOFTWARE (to be purchased separately)

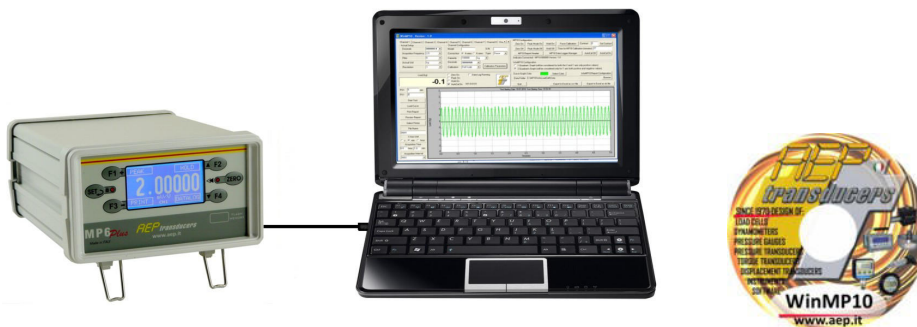

To complete the system of measurement **AEP transducers** has developed several software applications that interface directly to the instrument **MP6Plus** and support the user in the various functions of calibration, testing, analysis, data storage, transfer of measures on Microsoft Excel etc. ...

**MPSupervisor** is a software dedicated to **MP6Plus**. Through this software you can download the datalog and operate directly on **MP6Plus** to change parameters and create graphics test.

**Quick Analyzer** is a general-purpose acquisition software where **MP6Plus** can be associated to other **AEP instruments**. For dedicated calibration applications 3 different software are available: **ForceKal**, **PressKal**, **TorqueKal**.

For more information download the manuals of the software on the site:

[www.aeptransducers.com](http://www.aeptransducers.com)

[www.aep.it](http://www.aep.it)

### ForceKAL

Dedicated to the calibration of testing machines, test benches where force is generated.

Applied load kN	Cycle 1 kN	Cycle 2 kN	Cycle 3 kN	Average kN	Reading error %	Expanded uncertainty %
0.00	0.00	0.00		0.000	-	-
70.00	70.00	70.01		70.005	0.044	0.088
140.00	140.01	140.01		140.010	0.025	0.050
210.00	210.03	210.02		210.025	0.019	0.038
280.00	280.03	280.03		280.030	0.013	0.026
350.00	350.04	350.04		350.040	0.011	0.022

## PressKAL

Dedicated to the calibration of pressure gauges such as

- manometers
- pressure transducers
- pressure transmitters
- pressure switches

**Pressure gauge Sample**

Type: LabDMM Calibration Certificate: 54108P  
 Fondo Scala: 500 Unità: bar Numero di Serie: 504198  
 Baud rate: 9600 COM: 16 Decimal: 0000.00

**Receiving data and remote commands**

Sample Pressure: **249.92** bar

**Resolution:** 1, 2, 5, 10  
**Measure Unit:** mbar, kPa, psi, bar, MPa

**Zero:** On, Off  
**Pos. Peak:** On, Off  
**Neg. Peak:** On, Off

Devices DataBase: primo.dat

**Device in Calibration**

Type: PGE Object: Digital pressure gauge  
 Manufacturer: AEP transducers Serial number: 06001  
 Full Scale: 250 Unit: bar Resolution: 0.1  
 Calibration Certificate: CT00001

**Calibration chart**

Reference pressure bar	Cycle 1 Increasing pressure	Cycle 1 Diminishing pressure	Reading error bar	Expanded uncertainty bar	Reading error %	Exp.Uncert. no correct bar
0.00	0.00	0.00	0.000	0.071	0.000	0.071
25.00	24.96	24.96	-0.040	0.071	-0.008	0.111
75.00	74.96	74.96	-0.040	0.071	-0.008	0.111
125.00	124.94	124.94	-0.065	0.071	-0.013	0.136
200.00	199.92	199.92	-0.080	0.078	-0.016	0.158
250.00	249.92	249.92	-0.080	0.078	-0.016	0.158

**Calibration characteristics**

measurement points: 5 measurement type: Pressure

Calculate Errors: Calculate

Repeatability: **Start**

Accepts the measurement

## TORQUEKAL

Dedicated to the calibration of torque wrench with direct reading or snap.

**TorqueKal : Versione 3.8**

Coppia Applicata (Nm): **19**

Archivio Dispositivi: TORSIOMETER 100Nm

**Dispositivo in Taratura**

Tipo: DK50  
 Oggetto: Chiave Dinamometrica  
 Costruttore: Mabo  
 Numero di Serie: AD50-115674  
 Fondo Scala: 50 Nm  
 Unità di Misura: Nm  
 Risoluzione: 1 Nm  
 Certificato di Taratura: CT02-228756  
 Configurazione RS232: Canale Seriale COM6 Baud Rate 38400

**Tabella di Taratura**

Coppia Applicata	Ciclo 1	Ciclo 2	Ciclo 3	Ciclo 4	Ciclo 5	Coppia Applicata	Media	Scostamento	Incertezza
Nm	Nm	Nm	Nm	Nm	Nm	Nm	Nm	%	%
10.00	10.03	10.03	10.23	10.02	10.56	10.00	10.17	-1.710	4.618
30.00	29.99	31.30	30.50	30.45	31.21	30.00	30.69	-2.248	3.614
50.00	50.06	51.02	50.45	50.21	49.90	50.00	50.31	-0.612	1.846

**Caratteristiche della Taratura**

Decimals: #####  
 N. Misure: 1, 3  
 Punto 3: 50.00 Nm  
 Punto 2: 30.00 Nm  
 Punto 1: 10.00 Nm  
 Scostamento Ammissibile: 2.5%  
 Tipo di Misura: Taratura in senso Orotario

Calcolo Errori: L'altrezzo in taratura RIENTRA in tolleranza secondo la norma UNI EN ISO 6789

Log: Log Corrente, TORSIOMETER 100Nm

N.	Nome Dispositivo	Numero di Serie	Data	Ora	Tipo di Misura	Certificato N°	Scostamento Ammissibile	Risultato
10	Torsiometer 100Nm	AD50-115674	02/03/2013	16:16:27	Clockwise Calibration	CT02-228756	2.5%	OK
11	Torsiometer 100Nm	AD50-115674	03/03/2013	17:09:35	Clockwise Calibration	CT02-228756	2.5%	OK
12	Torsiometer 100Nm	AD50-115674	04/03/2013	09:08:55	Clockwise Calibration	CT02-228756	2.5%	OK
13	Torsiometer 100Nm	AD50-115674	05/03/2013	08:33:34	Clockwise Calibration	CT02-228756	2.5%	OK
14	Torsiometer 100Nm	AD50-115674	06/03/2013	10:56:22	Clockwise Calibration	CT02-228756	2.5%	OK
15	Torsiometer 100Nm	AD50-115674	07/03/2013	10:24:11	Clockwise Calibration	CT02-228756	2.5%	OK
16	Torsiometer 100Nm	AD50-115674	08/03/2013	11:22:25	Clockwise Calibration	CT02-228756	2.5%	OK
17	Torsiometer 100Nm	AD50-115674	09/03/2013	17:17:56	Clockwise Calibration	CT02-228756	2.5%	OK
18	Torsiometer 100Nm	AD50-115674	10/03/2013	13:09:29	Clockwise Calibration	CT02-228756	2.5%	OK
19	Torsiometer 100Nm	AD50-115674	11/03/2013	16:33:45	Clockwise Calibration	CT02-228756	2.5%	OK
20	Torsiometer 100Nm	AD50-115674	12/03/2013	16:12:11	Clockwise Calibration	CT02-228756	2.5%	OK
21	Torsiometer 100Nm	AD50-115674	13/03/2013	16:34:00	Clockwise Calibration	CT02-228756	2.5%	OK
22	Torsiometer 100Nm	AD50-115674	14/03/2013	10:23:56	Clockwise Calibration	CT02-228756	2.5%	OK
23	Torsiometer 100Nm	AD50-115674	15/03/2013	10:11:22	Clockwise Calibration	CT02-228756	2.5%	OK
24	Torsiometer 100Nm	AD50-115674	16/03/2013	11:00:13	Clockwise Calibration	CT02-228756	2.5%	OK
25	Torsiometer 100Nm	AD50-115674	17/03/2013	11:06:18	Clockwise Calibration	CT02-228756	2.5%	OK
26	Torsiometer 100Nm	AD50-115674	18/03/2013	09:11:19	Clockwise Calibration	CT02-228756	2.5%	OK
27	Torsiometer 100Nm	AD50-115674	19/03/2013	08:34:22	Clockwise Calibration	CT02-228756	2.5%	OK
28	Torsiometer 100Nm	AD50-115674	20/03/2013	09:21:44	Clockwise Calibration	CT02-228756	2.5%	OK
29	Torsiometer 100Nm	AD50-115674	21/03/2013	11:11:56	Clockwise Calibration	CT02-228756	2.5%	OK
30	Torsiometer 100Nm	AD50-115674	22/03/2013	15:33:04	Clockwise Calibration	CT02-228756	2.5%	OK

Numero Prove: 30 Prove In Tolleranza: 30 Prove Fuori Tolleranza: 0 cpk: 0.745 cp: 0.814



## QUICK ANALYZER

Dedicated to recording and graphical analysis of up to 16 different AEP transducers instruments to measure: force, weight, pressure, torque and displacement.

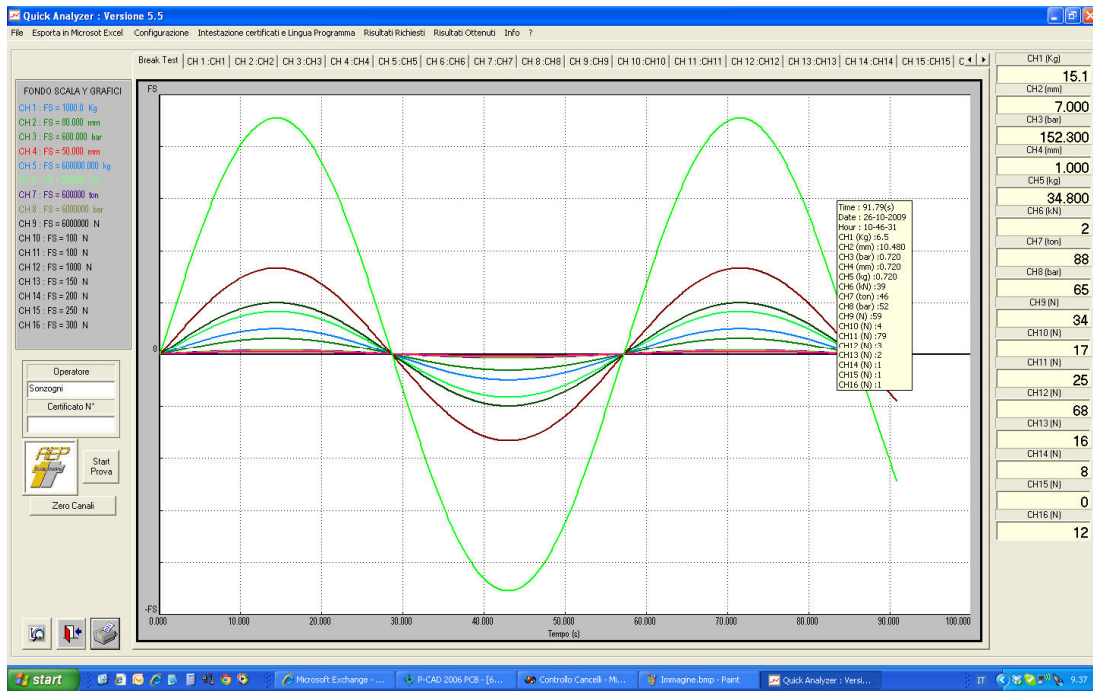

## MP Supervisor

A dedicated program that allows an immediate interfacing through the USB port with the MP6Plus and allows you to view graphs, export data to Microsoft Excel directly from the PC and set all configuration parameters. The program also allows you to download a data log carried out using the internal memory or the USB Flash Memory and display the respective curves of acquisition.

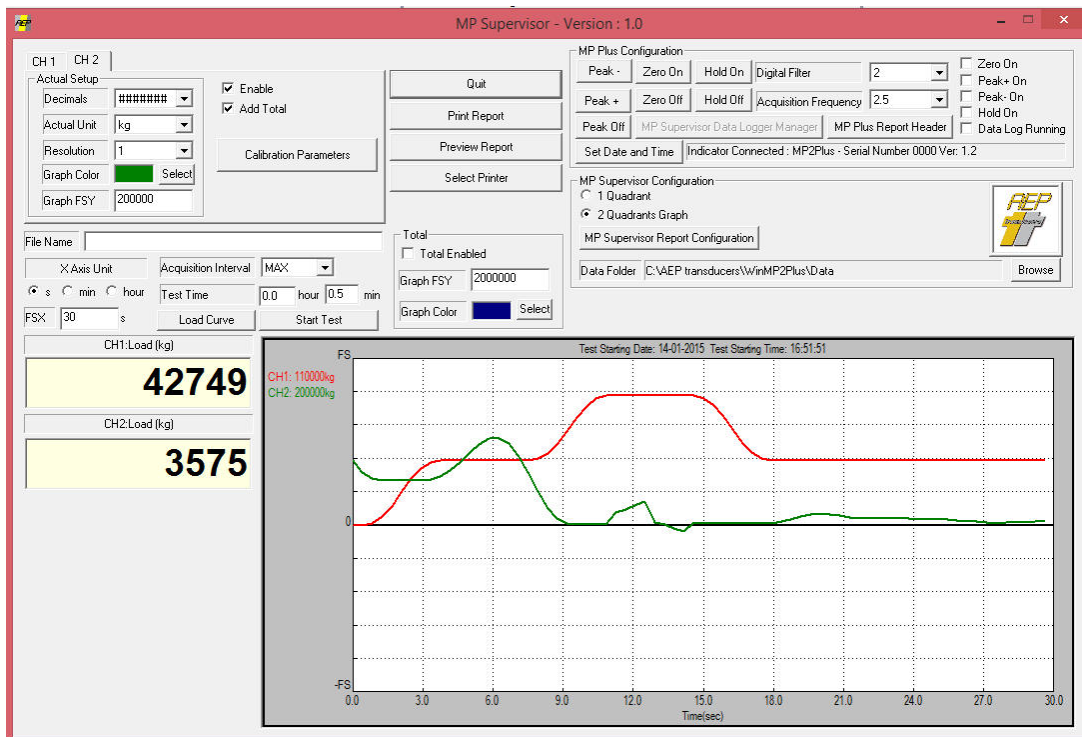

**Dimensions (mm) STANDARD VERSION**

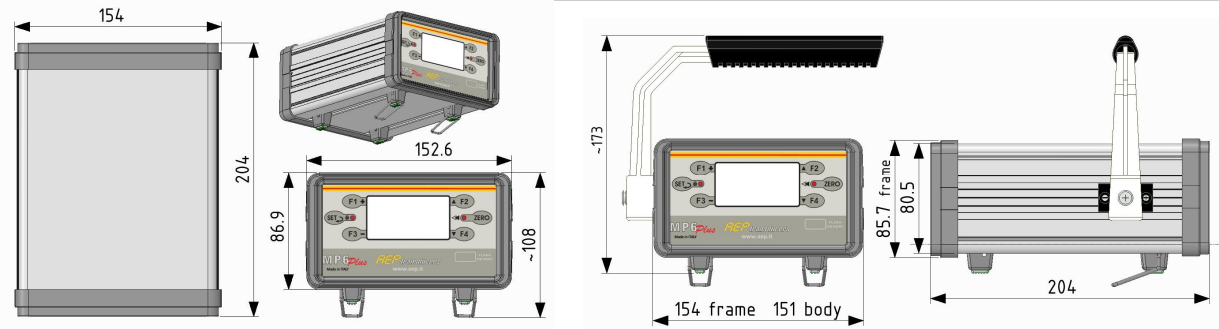

**MOUNTING PANEL APPLICATION**

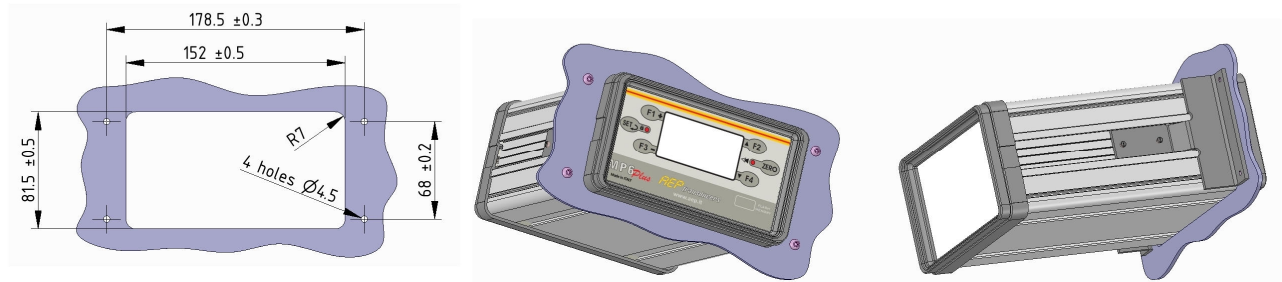

Note: For mounting panel requires 2 special brackets.

**PURCHASE CODES**

	Inputs	Power	Analog Output	Serial Output	Functions	Accessories	Digital Inputs
<b>MP6P</b>	<b>X</b>	<b>XXX</b>	<b>XX</b>	<b>X</b>	<b>X</b>	<b>X</b>	<b>X</b>
	<b>2</b> 2 inputs	<b>230</b> 230 Vac	<b>A1</b> 1 output	<b>S</b> RS232, RS458 Modbus, Printer	<b>D</b> Data logger Clock-Calendar	<b>M</b> Handle	<b>N</b> 4 Digital Inputs
	<b>3</b> 3 inputs	<b>115</b> 115Vac	<b>A2</b> 2 outputs	<b>W</b> Wireless Transmission	<b>F</b> Datalogger Clock-Calendar USB Flash Memory		
	<b>4</b> 4 inputs	<b>24</b> 24Vdc	<b>A3</b> 3 outputs				
			<b>A4</b> 4 outputs				

Example: **MP6P230** (MP6Plus power supply 230 Vac base version)

Example: **MP6P224A2SM** (MP6Plus 2 channels- power supply 24 Vdc + 2 Analog output + Serial output + handle)

Examples: **MP6P3115SF** (MP6Plus 3 channels power supply 115 Vac + Serial output + USB Flash Memory)



**ALWAYS SPECIFY** in the purchase order how to configure the input channels. After the sale, the inputs **can not be changed** by the customer.

Example of channel configuration **CH1**: 2mV/V, 4-20mA, ± 10V, POTENTIOMETER

Example of channel configuration **CH2**: 2mV/V, 4-20mA, ± 10V, POTENTIOMETER, PT100, ENCODER

Example of channel configuration **CH3**: 2mV/V, 4-20mA, ± 10V, POTENTIOMETER

Example of channel configuration **CH4**: 2mV/V, 4-20mA, ± 10V, POTENTIOMETER, PT100, ENCODER



41126 Cognento (MODENA) Italy Via Bottego 33/A Tel: +39-(0)59-346441 Fax: +39-(0)59-346437 E-mail: aep@aep.it

Al fine di migliorare le prestazioni tecniche del prodotto, la società si riserva di apportare variazioni senza preavviso.  
In order to improve the technical performances of the product, the company reserves the right to make any change without notice.